

GLOMIX-GLAXIARIS®-MIXER

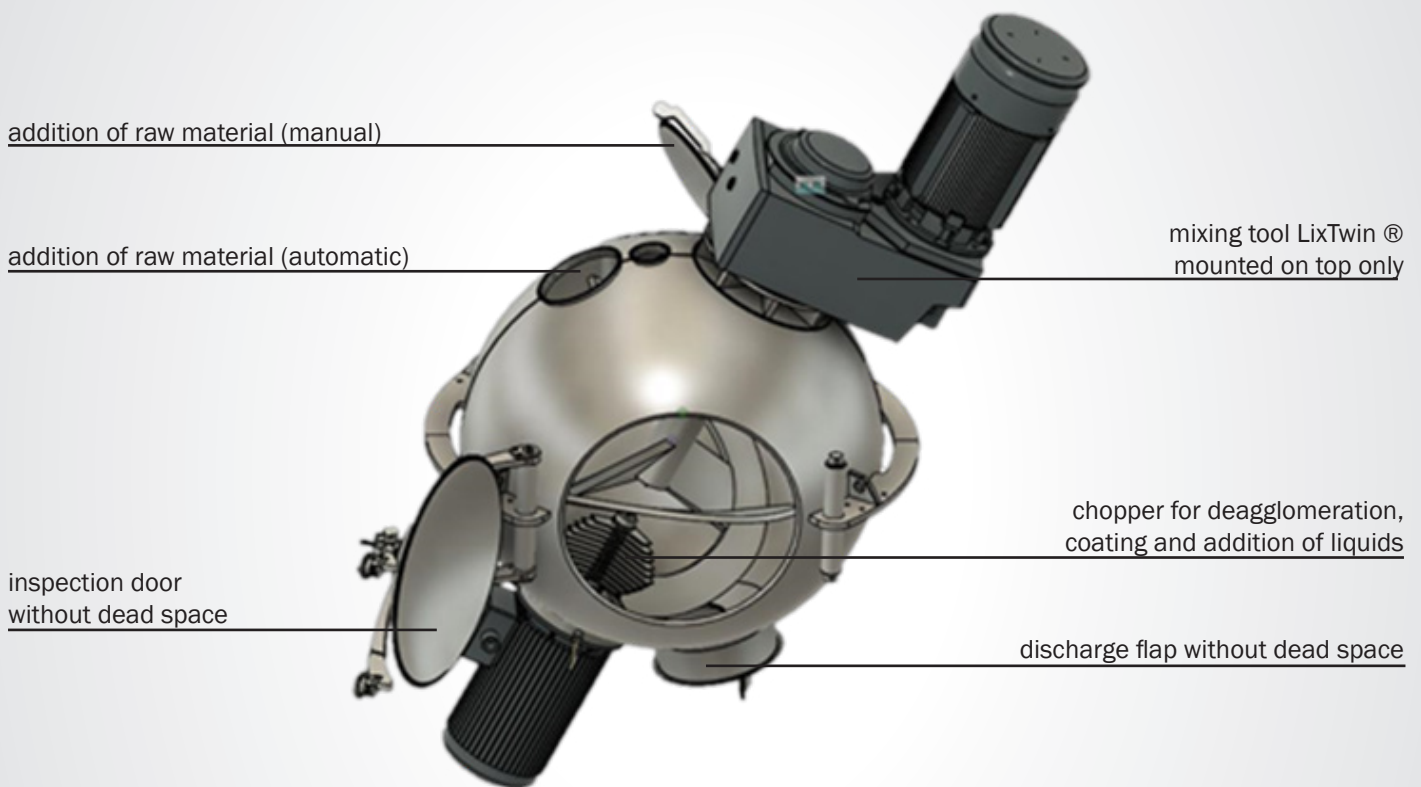

Ideally suited mixer for almost all mixing tasks. It combines strengths of vertical and horizontal mixing technology.

The Glomix-Glaxiaris®-Mixer offers:

- minimum mixing chamber surface, maximum usable volume
- gentle or intensive mixing
- short mixing time
- low energy input due to marginal friction and resistance
- addition of liquids possible
- fast wet and dry cleaning
- complete emptying
- and much more

Technical data

We manufacture mixers in laboratory size and in 100 litre increments:

Gross volume [l]	Net volumen [l]	Diameter [mm]	Wall thickness [mm]
600	500	1061	10
1000	800	1241	12
1300	1000	1337	12
1900	1500	1530	15
2500	2000	1684	15
3100	2500	1814	15
3800	3000	1928	20
4400	3500	2029	20
5000	4000	2122	20
6300	5000	2285	20

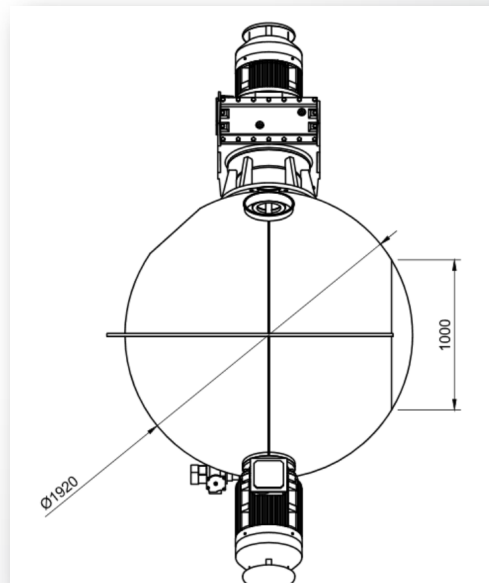
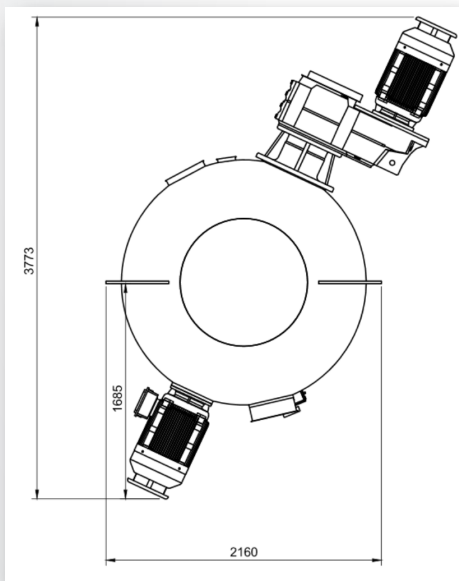

Illustrations: Dimensions of the Glomix-Glaxiaris® 3800 mixer with a gross volume of 3800 l and a useful volume of 80-90 %.